

Item description/product images



Description

Material, version:

Body carbon steel, hardened and black oxidised.
Locating pin hardened tool steel.

Note:

* The conical spigot can position holes within these limits.

mounting hole

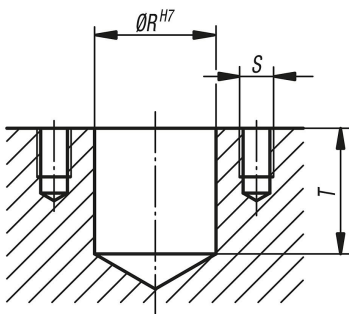

Drawings

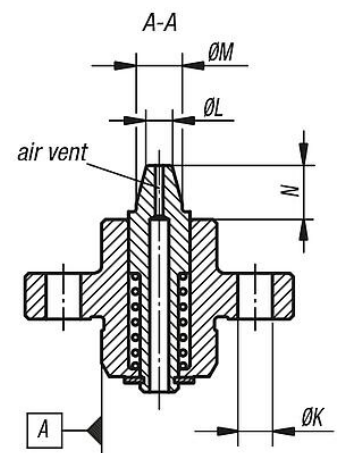
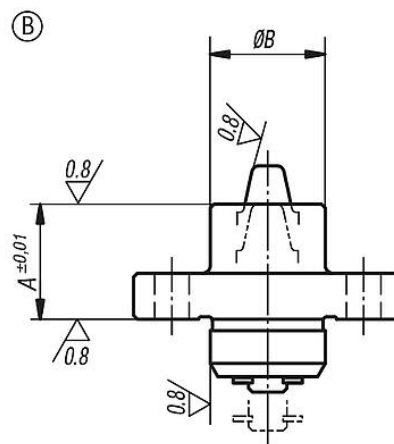
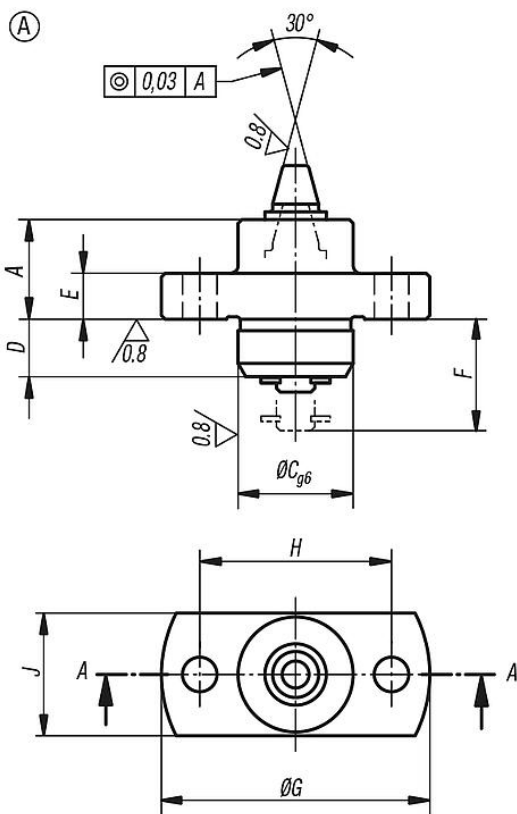

Drawings

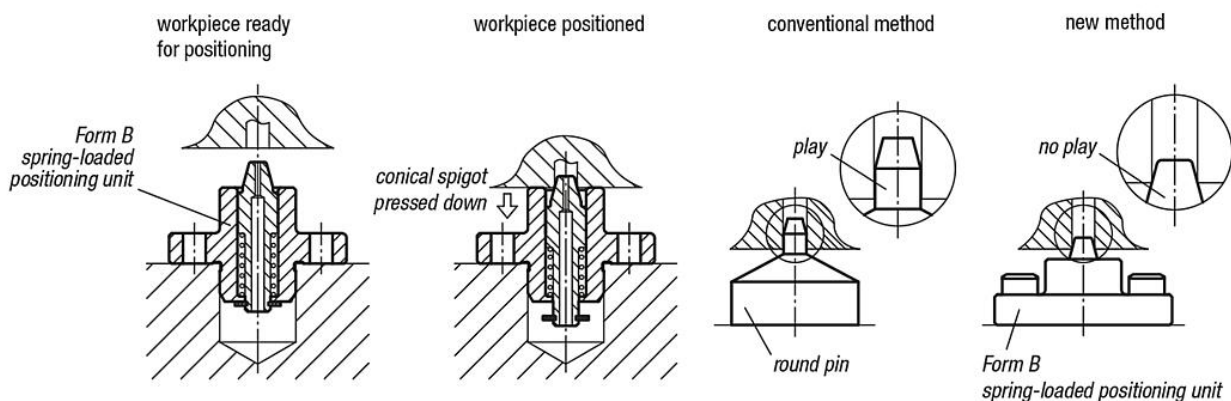

The conical spigot is pushed down when the workpiece is mounted on the positioning unit.

The conical spigot ensures precise positioning.

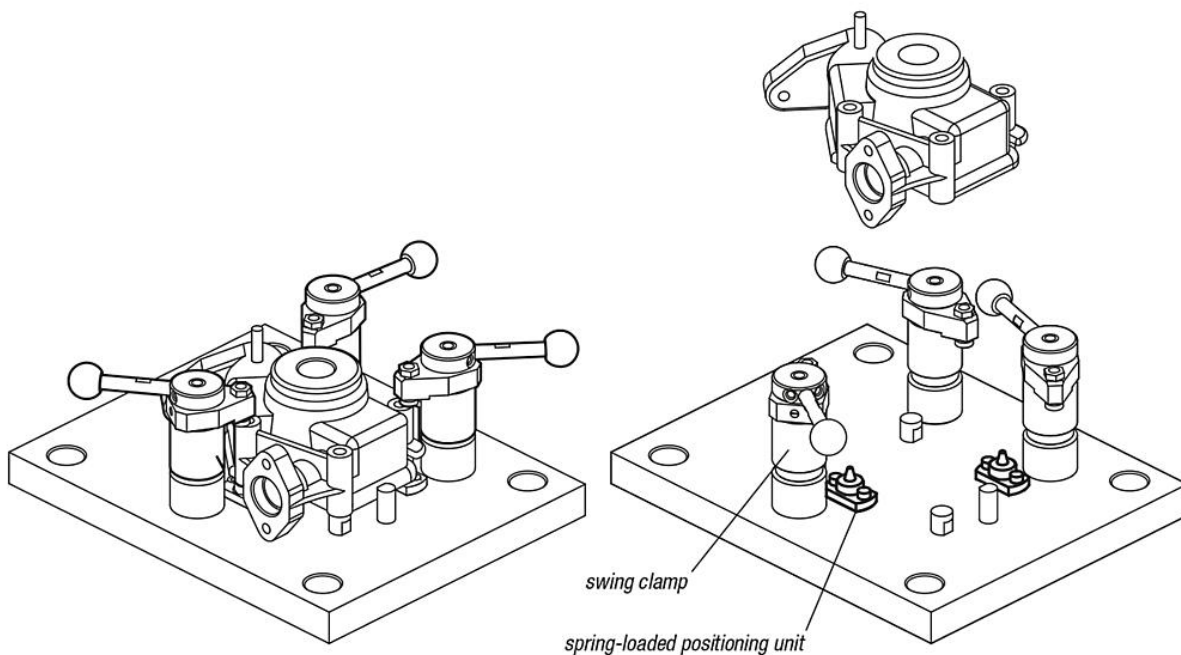

Note:
To prevent the positioning unit lifting the workpiece, hold it down by hand when loosening the swing clamp.

Overview of items

Order No.	Form	A	B	C	D	E	F	G	H	J	K	L	M	N	R	S	T	Receiving hole	Spring force cone N
03170-15060	A	13	15	15	7,5	6	15	35	25	16	4,5	3,5	6	7,4	15	M4	16	ø3,8 - ø5,2*	6,4 - 19,3
03170-15070	A	13	15	15	7,5	6	15	35	25	16	4,5	4,5	7	7,4	15	M4	16	ø4,8 - ø6,2*	6,4 - 19,3
03170-20090	A	18	20	20	10	8	20	40	30	22	4,5	5,5	9	9,3	20	M4	21	ø5,8 - ø8,2*	5,5 - 20,5
03170-20110	A	18	20	20	10	8	20	40	30	22	4,5	7,5	11	9,3	20	M4	21	ø7,8 - ø10,2*	5,5 - 20,5

Overview of items

Order No.	Form	A	B	C	D	E	F	G	H	J	K	L	M	N	R	S	T	Receiving hole	Spring force cone N
03170-15061	B	15	15	15	7,5	6	15	35	25	16	4,5	3,5	6	5,4	15	M4	16	ø3,8 - ø5,2*	6,4 - 19,3
03170-15071	B	15	15	15	7,5	6	15	35	25	16	4,5	4,5	7	5,4	15	M4	16	ø4,8 - ø6,2*	6,4 - 19,3
03170-20091	B	20	20	20	10	8	20	40	30	22	4,5	5,5	9	7,3	20	M4	21	ø5,8 - ø8,2*	5,5 - 20,5
03170-20111	B	20	20	20	10	8	20	40	30	22	4,5	7,5	11	7,3	20	M4	21	ø7,8 - ø10,2*	5,5 - 20,5