

Item description/product images



Description

Material:

Grip and set screw aluminium.
Bush and pin steel 5.8.

Version:

Grip and set screw anodised.
Bushes black oxidised, pins electro zinc-plated.

Note:

The required torque is set by a set screw and a graduated scale. The set value can be secured using the lateral clamping screw. When the set torque is reached the grip audibly and palpably releases. The loosening torque is higher than the tightening torque so that the torque handle can be released without any problems.

The internal thread version has a hole in the set screw so that the torque handle can also be used on threaded rods.

Set torque accuracy $\pm 5\%$.

On request:

Other thread lengths.

Drawings

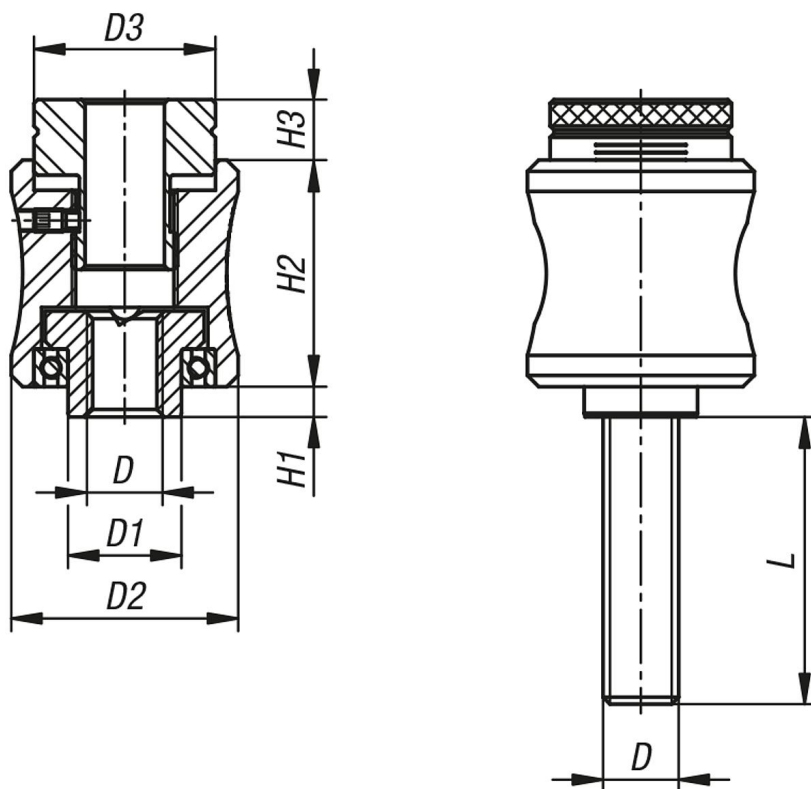

Overview of items

Internal thread

Order No.	D	D1	D2	D3	H1	H2	H3	Torque Nm
07124-105	M5	10	26	20	2	26	8	0,05 - 0,1
07124-106	M6	10	26	20	2	26	8	0,1 - 0,25
07124-208	M8	15	30	24	4	30	8	0,25 - 0,5
07124-210	M10	15	30	24	4	30	8	0,5 - 1

External thread

Order No.	D	D1	D2	D3	H1	H2	H3	L	Torque Nm
07124-105X30	M5	10	26	20	2	26	8	30	0,05 - 0,15
07124-105X40	M5	10	26	20	2	26	8	40	0,05 - 0,15
07124-106X30	M6	10	26	20	2	26	8	30	0,1 - 0,25
07124-106X40	M6	10	26	20	2	26	8	40	0,1 - 0,25
07124-208X40	M8	15	30	24	4	30	8	40	0,25 - 0,5
07124-208X50	M8	15	30	24	4	30	8	50	0,25 - 0,5
07124-210X40	M10	15	30	24	4	30	8	40	0,5 - 1
07124-210X50	M10	15	30	24	4	30	8	50	0,5 - 1