

Item description/product images



**Description**

**Material:**  
Steel.

**Version:**  
Hardened and ground (HRC 60 ±2).

**Note:**  
The locating pins are designed to make the joining process easier. Used in combination with hardened locating bushes 02026, they enable exact, low-wear, and fast changes of the workpiece.

Versions D1 = 5 and D1 = 6 do not have an internal thread.

**Drawing reference:**  
Form B: cylindrical pin  
Form C: rhomboid pin

Drawings

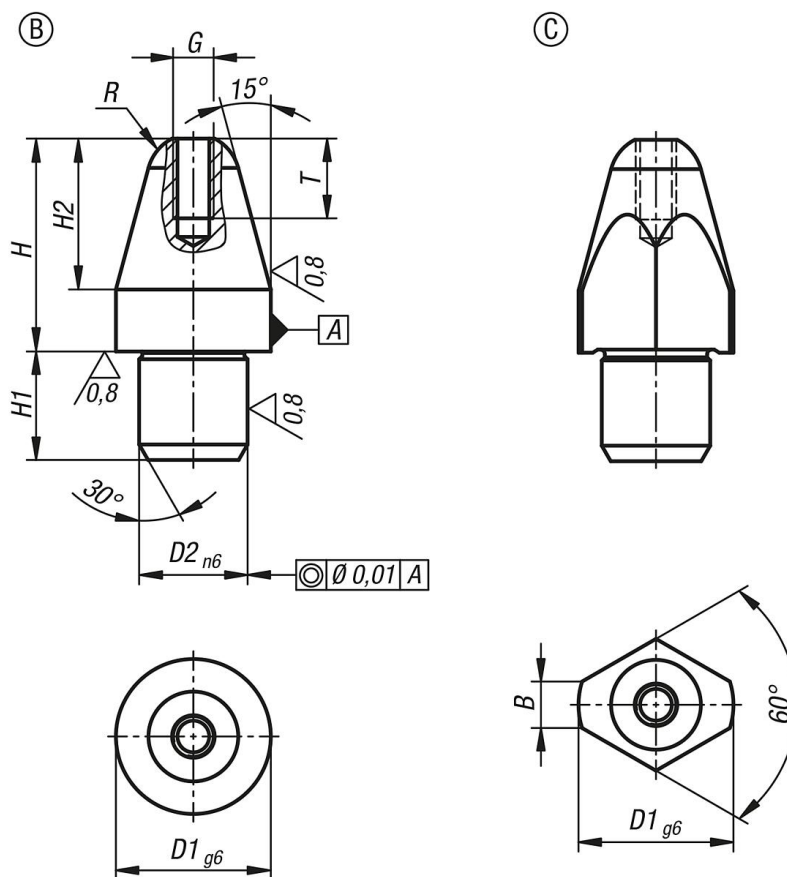

Overview of items

Order No.	Form	Version 1	B	D1	D2	G	H	H1	H2	R	T
02025-205	B	short	-	5	3	-	8	3	5	1,50	-
02025-206	B	short	-	6	4	-	10	4	6	1,80	-
02025-208	B	short	-	8	6	M2,5	11,4	6	7,4	2,5	5
02025-210	B	short	-	10	7	M2,5	13,7	7	9,7	3	5

## Overview of items

Order No.	Form	Version 1	B	D1	D2	G	H	H1	H2	R	T
02025-212	B	short	-	12	8	M3	16	8	12	3,5	6
02025-216	B	short	-	16	12	M4	20	12	15	5	8
02025-220	B	short	-	20	14	M5	25,5	14	19,5	6	10
02025-305	B	long	-	5	3	-	10	3	5	1,50	-
02025-306	B	long	-	6	4	-	12	4	6	1,80	-
02025-308	B	long	-	8	6	M2,5	17,4	6	7,4	2,5	5
02025-310	B	long	-	10	7	M2,5	21,7	7	9,7	3	5
02025-312	B	long	-	12	8	M3	24	8	12	3,5	6
02025-316	B	long	-	16	12	M4	29	12	15	5	8
02025-320	B	long	-	20	14	M5	35,5	14	19,5	6	10
02025-405	C	short	-	5	3	-	8	3	5	1,50	-
02025-406	C	short	-	6	4	-	10	4	6	1,80	-
02025-408	C	short	2,5	8	6	M2,5	11,4	6	7,4	2,5	5
02025-410	C	short	3,0	10	7	M2,5	13,7	7	9,7	3	5
02025-412	C	short	3,5	12	8	M3	16	8	12	3,5	6
02025-416	C	short	5	16	12	M4	20	12	15	5	8
02025-420	C	short	6	20	14	M5	25,5	14	19,5	6	10
02025-505	C	long	-	5	3	-	10	3	5	1,50	-
02025-506	C	long	-	6	4	-	12	4	6	1,80	-
02025-508	C	long	2,5	8	6	M2,5	17,4	6	7,4	2,5	5
02025-510	C	long	3,0	10	7	M2,5	21,7	7	9,7	3	5
02025-512	C	long	3,5	12	8	M3	24	8	12	3,5	6
02025-516	C	long	5	16	12	M4	29	12	15	5	8
02025-520	C	long	6	20	14	M5	35,5	14	19,5	6	10