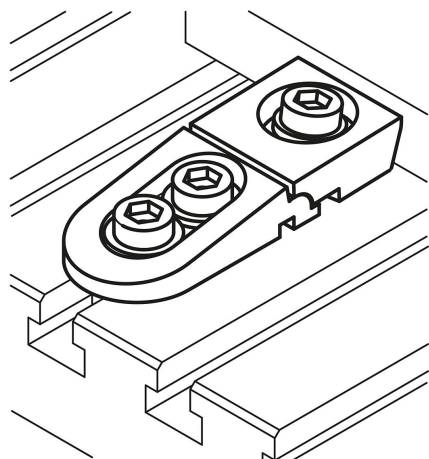

## Item description/product images

**Description****Material:**

Clamping element (front) steel 1.7225.  
Retaining element (rear) steel 1.0503.  
Cap screws and slot keys grade 8.8 steel.

**Version:**

Body parts hardened and nickel-plated.  
Fasteners black oxidised.

**Note:**

Particularly low workpieces can be clamped using the T-slot clamps. The positive down force helps to hold the workpiece down on the machine table.

**Application:**

1. Slide the clamp in the machine table T-slot up to the workpiece.
2. Tighten the fastening screws with the appropriate torque.
3. Tighten the clamping screw to clamp the workpiece in place.

Drawings

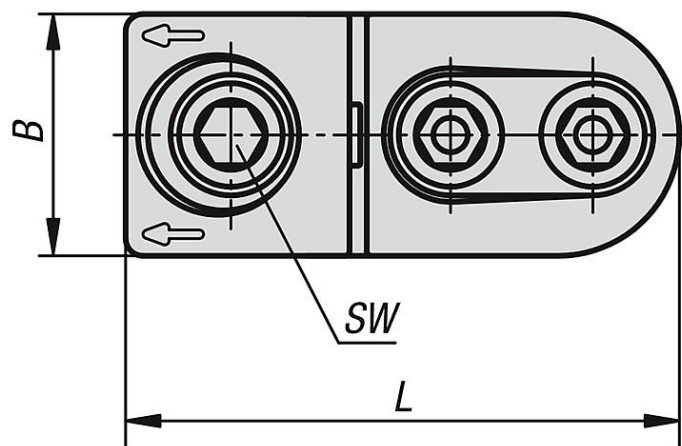
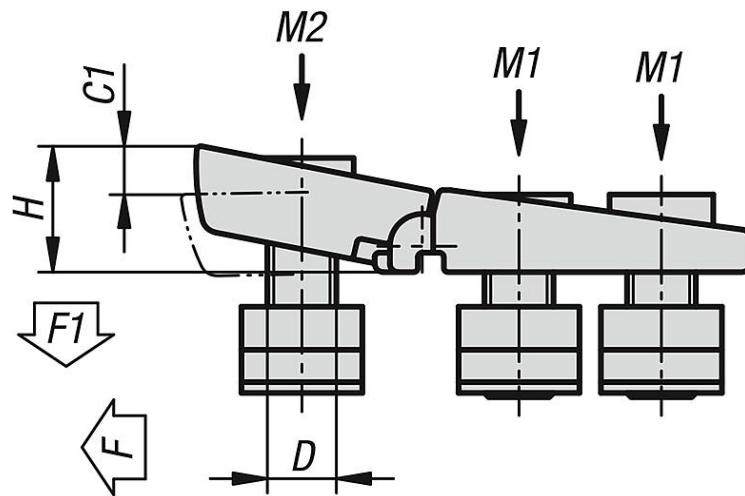

Overview of items

Order No.	Slot width	B	C1	D	H	L	SW	F kN	F1 kN	Tightening torque M1 Nm	Tightening torque M2 Nm
04462-1214	14	44	8	M12	25	112	10	15	7,5	65	52
04462-1618	18	56	10	M16	30	132	14	25	12,5	150	120
04462-2022	22	62	11	M20	35	155	17	36	18	300	240