

## Item description/product images

**Description**

**Material:**  
Spring steel

**Version:**  
Electro zinc-plated.

**Note:**  
Retaining washer for fastening the locking pin. This keeps the locking pin joined captively to the cover.

**Accessory:**  
Quarter turn latches 05592-50.

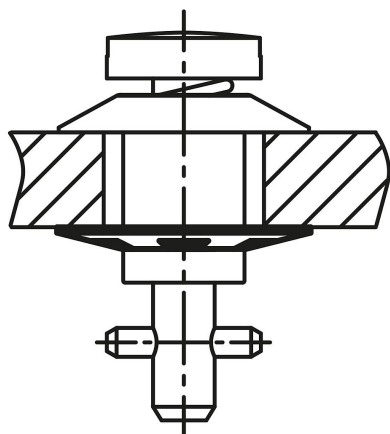

Drawings

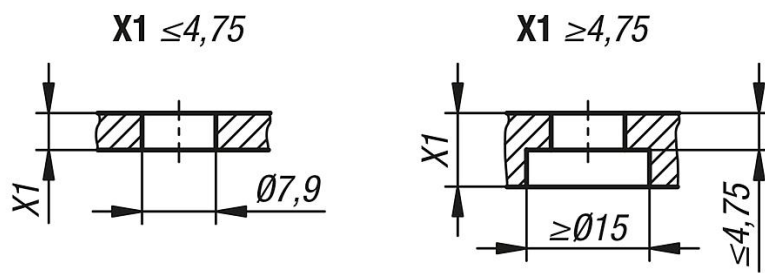
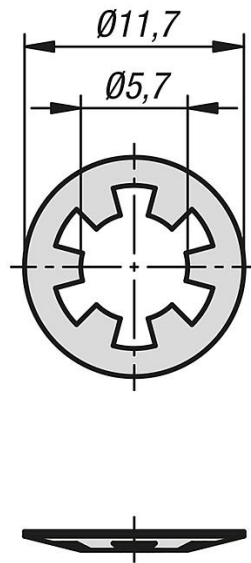

Overview of items

Order No.	Item	for Art. No.
05592-51-06	Retaining washer	05592-50