

Item description/product images

**Description****Material:**

Die-cast zinc.

Version:

Black powder-coated, high-gloss chromed or matt chromed.

Note:

Latches for the easy and secure locking of doors and hatches. The toggle system makes them vibration proof.

The latches can be screwed on or riveted. We recommend using M3 countersunk screws to fasten the components.

The die-cast housing conceals all functional parts and so secures against dismantling when closed.

2 keys are supplied with the version that has a cylinder lock. The key can be removed in both positions (open and closed). The locks have a single key system, i.e. all locks can be opened with the same key.

Max. load capacity is 1,200 N.

Supplied with catch plate.

Drawings

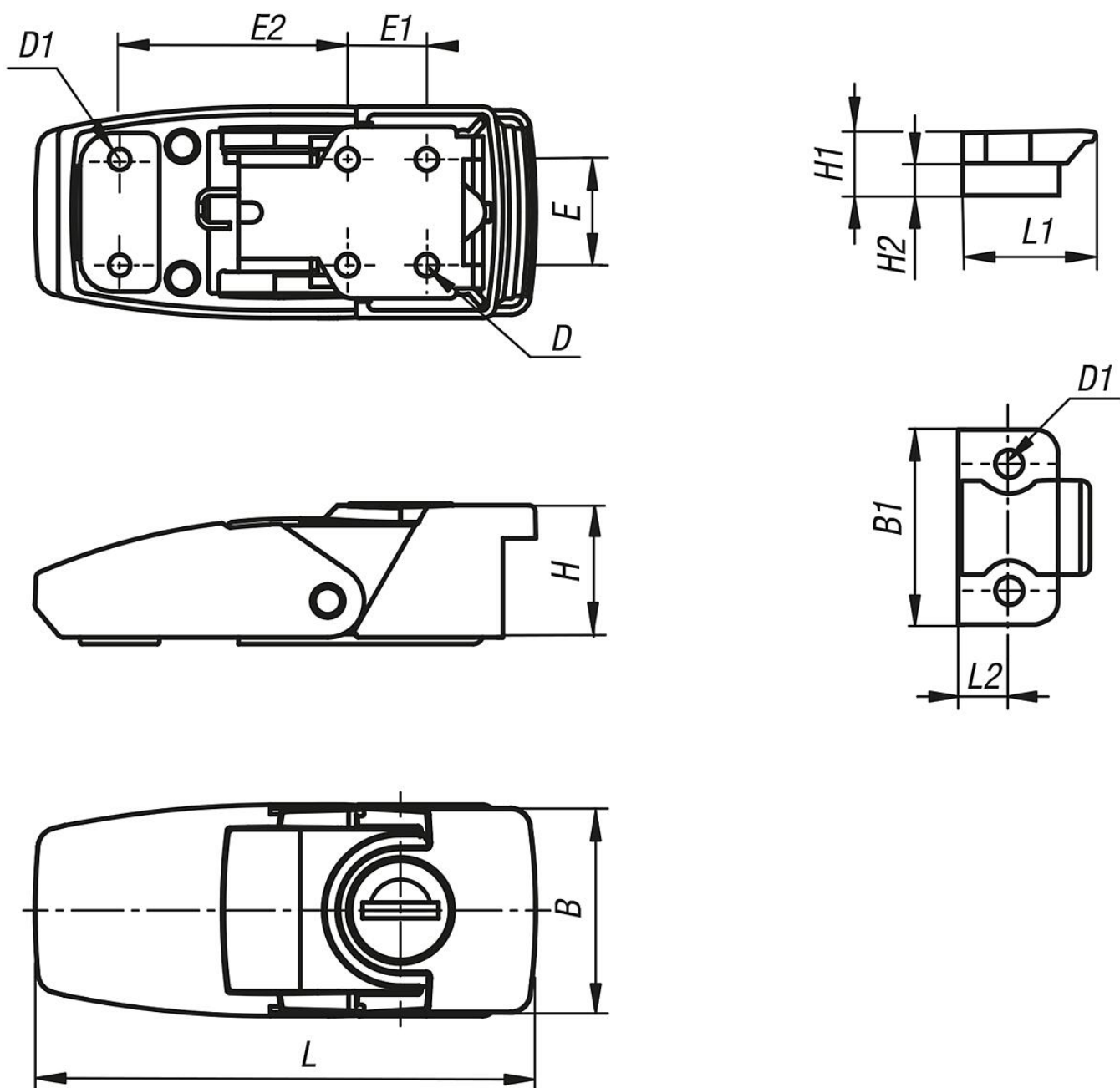

Overview of items

Order No.	Version 1	Main colour	Surface finish body	L	B	H	B1	D	D1	E	E1	E2	H1	H2	L1	L2
05547-10-11064	lockable	black	powder-coated	64,8	26,5	18	19,7	3,2	3,2	12	12	30	6,5	3,5	15,5	6
05547-10-21064	lockable	-	high-gloss chromed	64,8	26,5	18	19,7	3,2	3,2	12	12	30	6,5	3,5	15,5	6
05547-10-31064	lockable	-	matt chromed	64,8	26,5	18	19,7	3,2	3,2	12	12	30	6,5	3,5	15,5	6
05547-10-11076	lockable	black	powder-coated	76	32	21	24	3,2	3,2	16	12	34,6	8	4	16	6
05547-10-21076	lockable	-	high-gloss chromed	76	32	21	24	3,2	3,2	16	12	34,8	8	4	16	6
05547-10-31076	lockable	-	matt chromed	76	32	21	24	3,2	3,2	16	12	34,1	8	4	16	6

