

Technical Information Quarter-turn clamp lock 05592-12 and clamping plate 05592-30

1. Application:

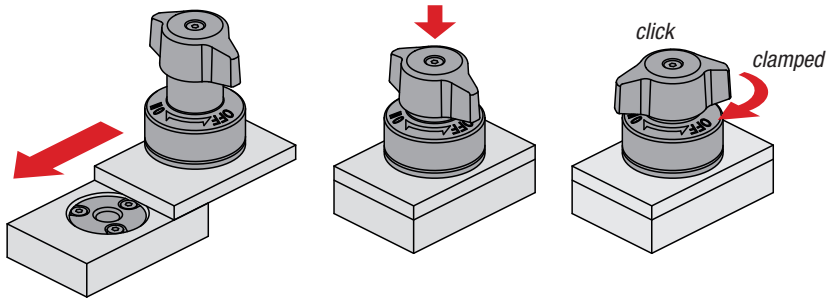

Ensure that the twist knob is in the „OFF“ position.
 Push or place the quarter-turn clamp lock over the pre-mounted clamping plate.
 Press the twist knob down and turn it to the „ON“ position.
 When fully clamped, an audible click will be heard.

2. Function:

The shaft retracts in the unlocked position to allow you to work without affecting the base plate.

When the turnbuckle and clamping plate components are joined together, the groove moves along the balls in the clamping plate as it turns. The spring is pressed together and clamps the components.

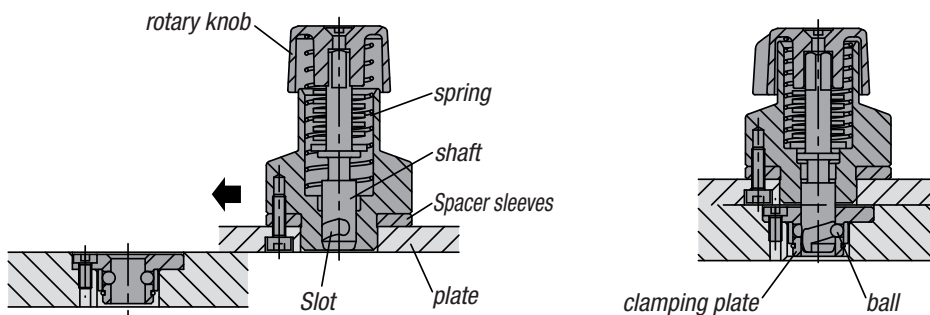

Repeat accuracy:

A higher repeat accuracy can be achieved with the aid of additional locating pins (not supplied).

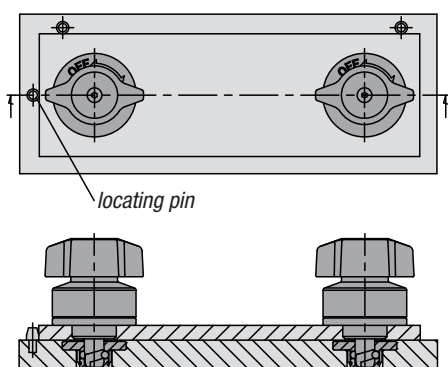

Production tolerances:

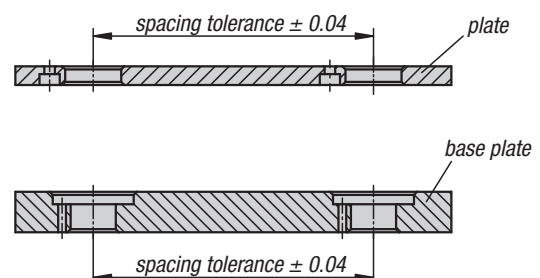

Application examples:

