

Technical Information

Locking pin 03192-30

Note:

These are designed to quickly clamp 2 plates.

The system can be used for changing mechanisms in assembly applications or for making other manual adjustments, such as conversions in automatic systems.

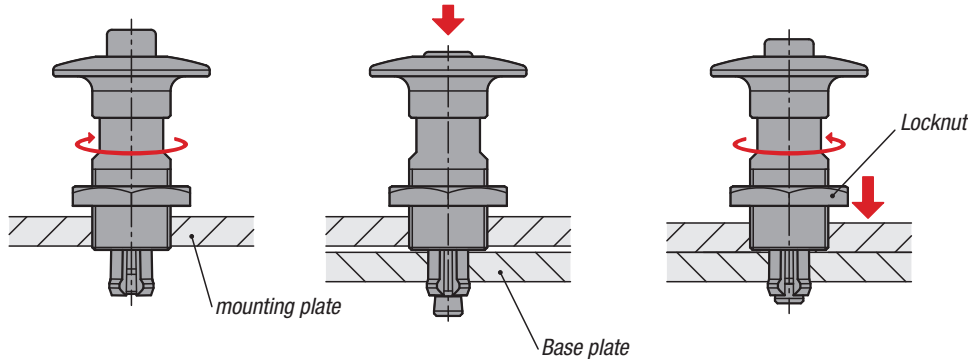

Screw the locking pin into the mounting plate until the thread can be seen on the other side.

Press the knob and pass the clamping pin through the hole in the premachined baseplate.

Screw the locking pin in the reverse direction till both plates come together, then secure with the locknut.

Assembly:

The mounting situation is customer specific. Plates of different thicknesses can be joined.

Repeat accuracy:

A higher repeat accuracy can be achieved with the aid of additional locating pins (not supplied).

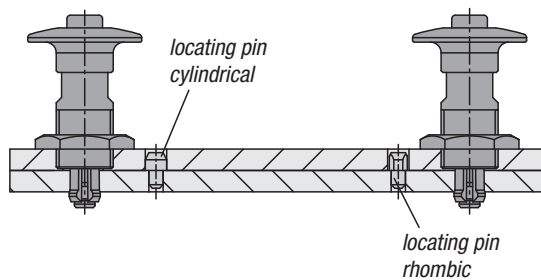

Recommended tolerances when using 2 items

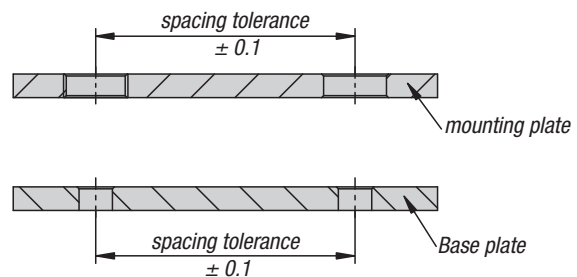

Attention:

Use a hard material such as stainless steel for the baseplate.

Mounting hole in the mounting plate

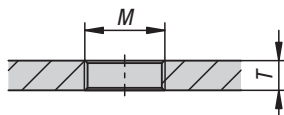

Mounting hole in the base plate

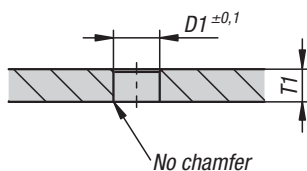

Application example:

Changing retainer plates

