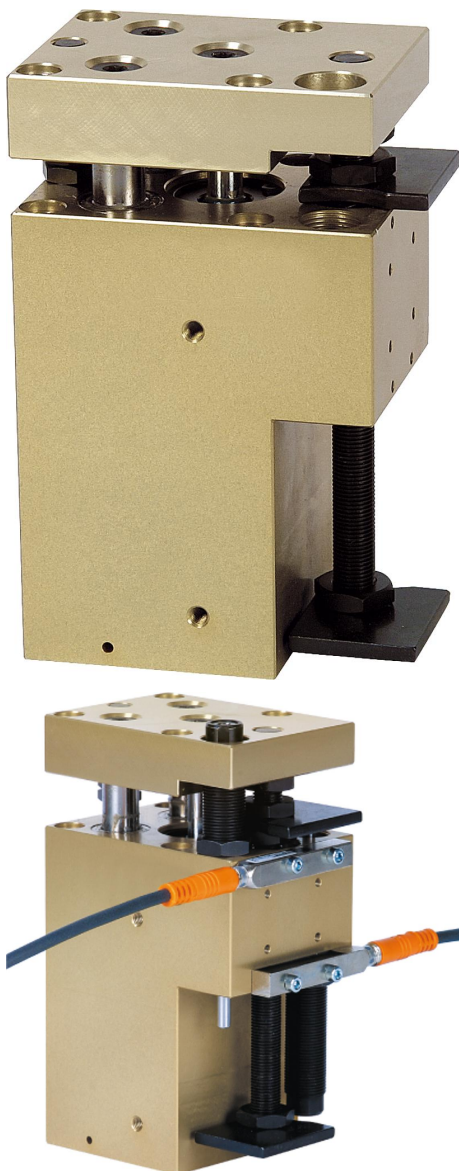

Item description/product images

**Description****Material:**

Housing high-strength aluminium.
Stop system steel.

Version:

Housing anodised.
Stop system hardened and black oxidised.

Note:

Highly robust maintenance-free pneumatic lifting units with sealed ball guide.
Control by 4/2 or 5/2 directional valve. Pneumatic drive, 4-8 bar, constant, filtered (10 µm), dried, oiled or unoled. Compressed air connection M5.
Modules of the same size can be combined with one another without adapter plates via the precise centring system by means of centring rings 20240.

Repeat accuracy ± 0.02 mm.

On request:

Lifting units with shorter strokes available.

Accessory:

See table for shock absorbers, proximity switches and plug connectors.

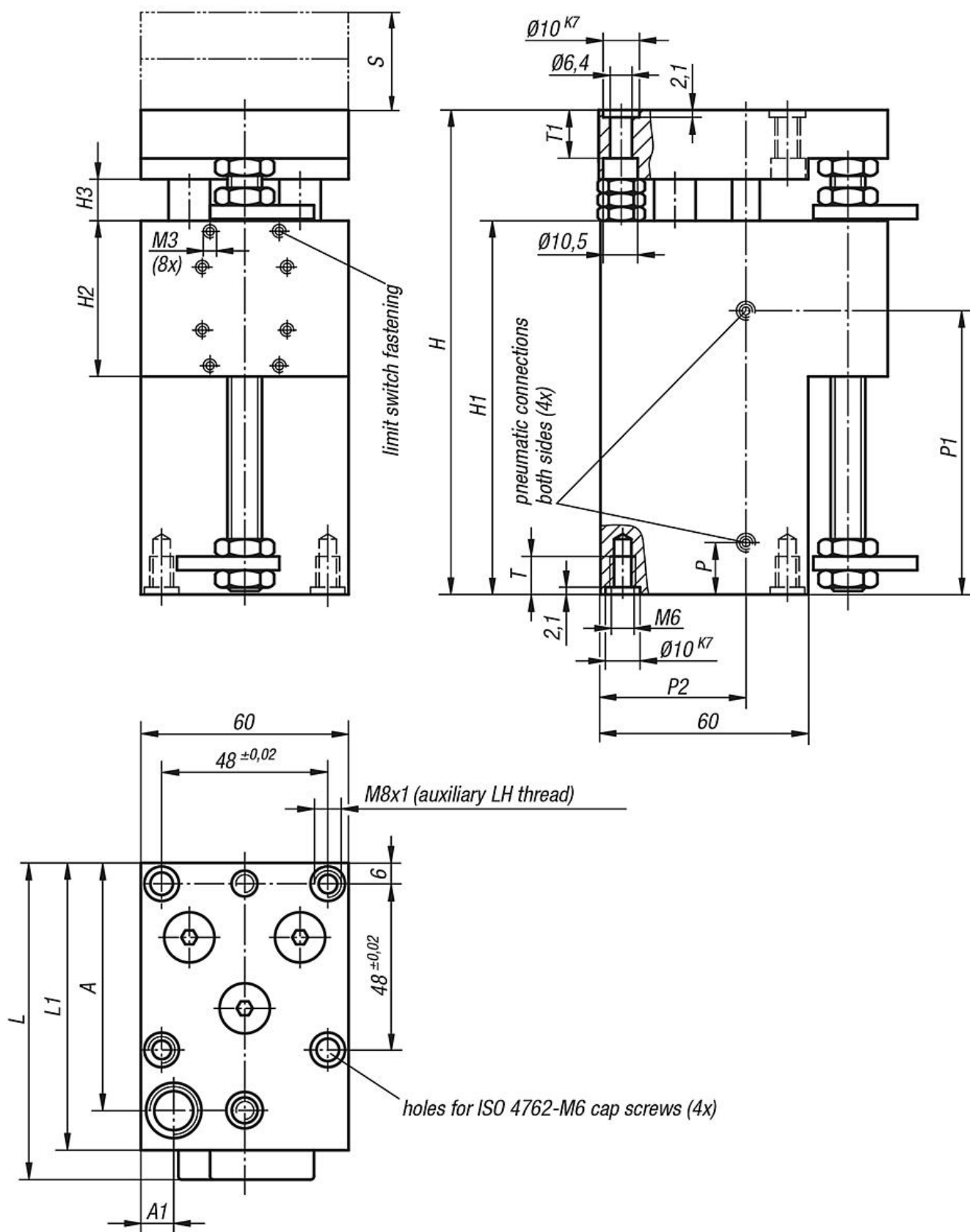

Load data

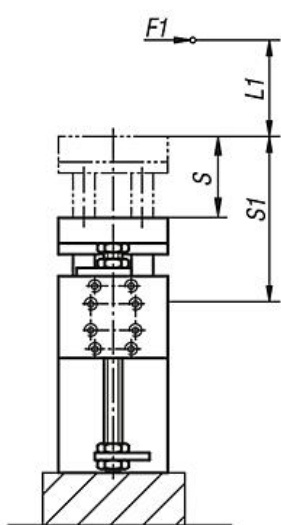

$$M1 = (S1 + L1) \times F1$$

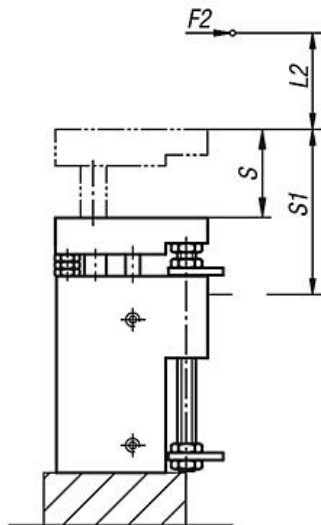

$$M2 = (S1 + L2) \times F2$$

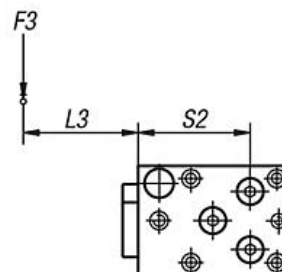

$$M3 = (S2 + L3) \times F3$$

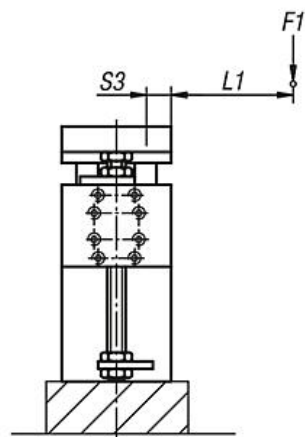

$$M1 = (S3 + L1) \times F1$$

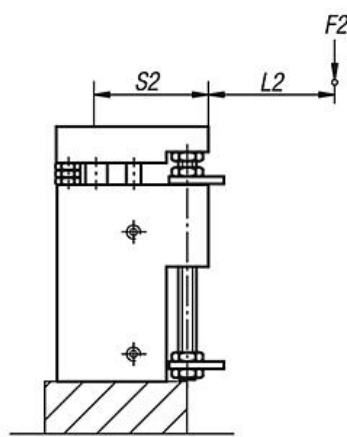

$$M2 = (S2 + L2) \times F2$$

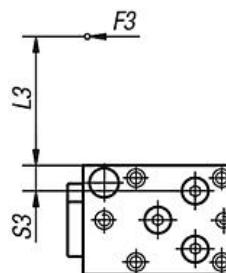

$$M3 = (S3 + L3) \times F3$$

$$\frac{M1_{eff}}{M1_{zul}} + \frac{M2_{eff}}{M2_{zul}} + \frac{M3_{eff}}{M3_{zul}} \leq 1$$

Calculating the lifespan:

$$L = \left(\frac{M_{zul}}{M_{eff}} \right)^3 \times 10^5$$

- L = lifespan (m)
- M_{zul} = permissible torque (Nm)
- M_{eff} = calculated torque (Nm)

Overview of items

Order No.	Size	A	A1	H	H1	H2	H3	L	L1	P	P1	P2	Travel S	T	T1
20054-6050	6	71,5	10	140	108	45	12	92	83	15	83	41,5	50	16	13
20054-6075	6	71,5	10	165	133	45	12	92	83	15	108	41,5	75	16	13
20054-6100	6	71,5	10	190	158	45	12	92	83	15	133	41,5	100	16	13

Order No.	Size	Piston force at 6 bar (N)	Retraction force at 6 bars (N)	Cylinder Ø	Air consumption per cycle at 6 bar (ccm)	Suitable shock absorber	Suitable proximity switch	Suitable plug connector
20054-6050	6	220	200	25	33	26310-1410012	83000-05-010	80150-010X2000
20054-6075	6	220	200	25	50	26310-1410012	83000-05-010	80150-010X2000
20054-6100	6	220	200	25	66	26310-1410012	83000-05-010	80150-010X2000

Order No.	Size	M1 Nm	M2 Nm	M3 Nm	S1	S2	S3
20054-6050	6	28	28	30	46 + S/2 (travel)	61	14
20054-6075	6	28	28	30	46 + S/2 (travel)	61	14
20054-6100	6	28	28	30	46 + S/2 (travel)	61	14