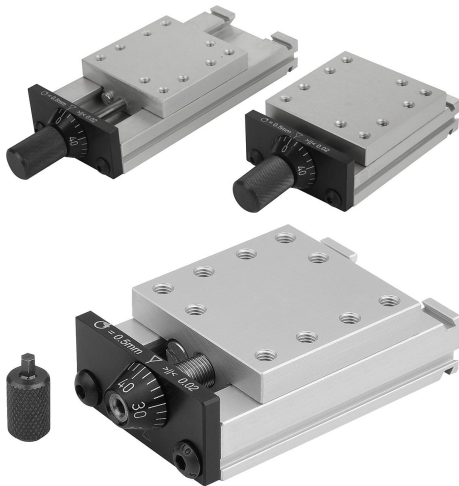

## Item description/product images

**Description****Material:**

Aluminium EN AW-6063

**Note:**

These precision dovetail slides find use in e.g. machine and fixture construction, metrology, optical instruments and fine mechanics.  
The stated permissible load rating (F) is for static loads.  
The torque values only apply for centred carriages.  
The micrometer knurled knob for moving the carriage is pressed on.

M1 = countersink for screw

TI = number of fastening holes E1/E2/M1 inside.

TA = number of fastening holes E/E1/MA outside.

**Advantages:**

- Innovative and safe clamping system without height or lateral displacement.
- No play in guides.
- Rapid subsequent combination in X, Y and Z axes.

**Applications:**

- Adjustment of machining units, metrology cameras, mirrors, microscopes and laser heads (including the machining of surgical needles).
- Fine adjustment of brazing, plasma and welding heads.
- Focussing of flame nozzles.

Drawings

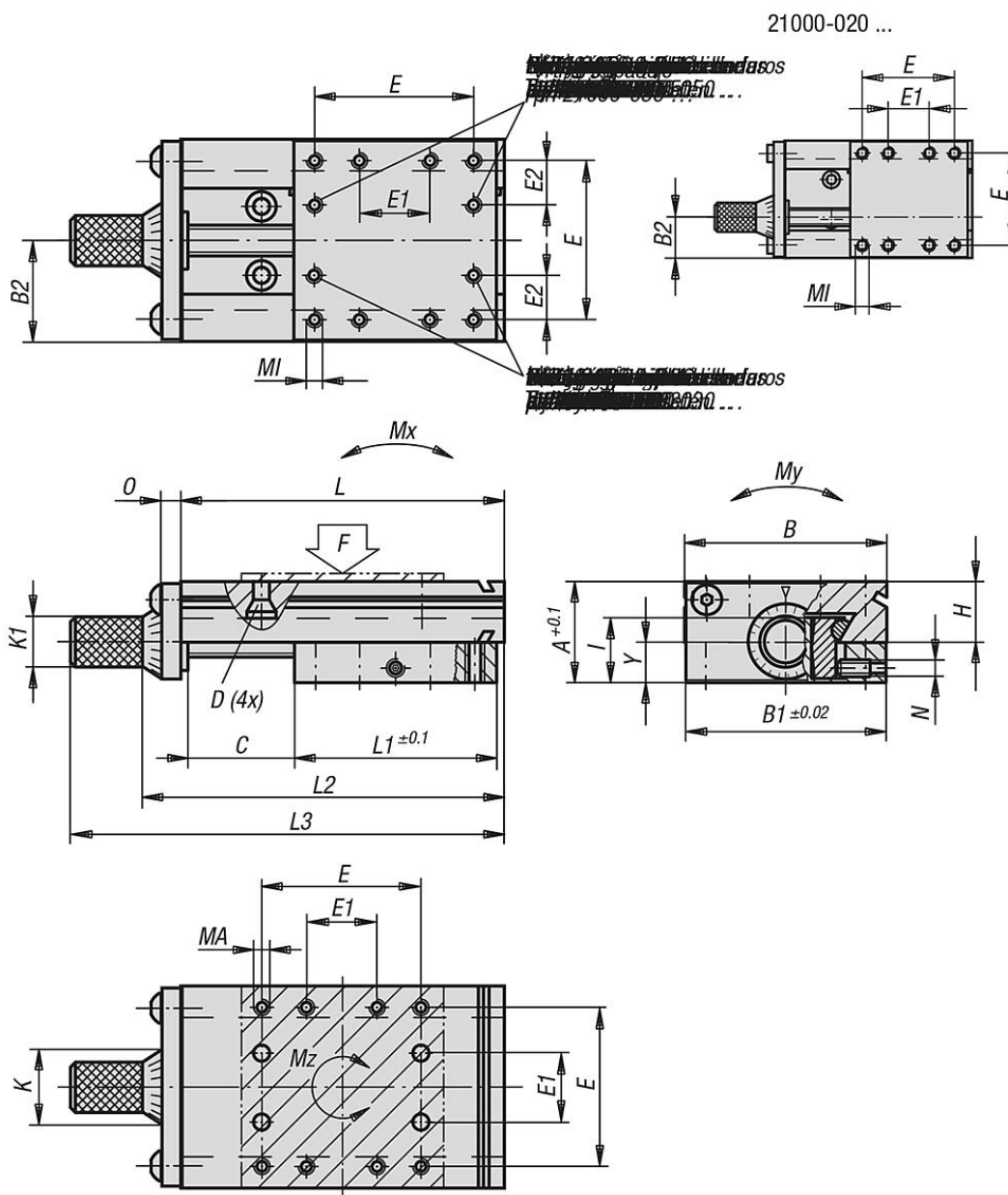

Overview of items

Order No.	A	B	B1	B2	D for screw	E	E1	E2	T1	TA	H	I	K	K1	Travel S
21000-020030	13	20 -0,3	19,6	8,1	M2	12	6	-	8	8	8	8,3	10	6,3	5
21000-020035	13	20 -0,3	19,6	8,1	M2	12	6	-	8	8	8	8,3	10	6,3	10
21000-020045	13	20 -0,3	19,6	8,1	M2	12	6	-	8	8	8	8,3	10	6,3	20
21000-030040	15	30 -0,3	29,6	13	M3	23	8	7,5	10	8	9,8	9,8	10	6,3	5
21000-030045	15	30 -0,3	29,6	13	M3	23	8	7,5	10	8	9,8	9,8	10	6,3	10
21000-030055	15	30 -0,3	29,6	13	M3	23	8	7,5	10	8	9,8	9,8	10	6,3	20
21000-050067	23	50 -0,3	49,4	25	M4	38	16	11	10	8	14,5	15,6	22	14,3	12
21000-050080	23	50 -0,3	49,4	25	M4	38	16	11	10	8	14,5	15,6	22	14,3	25
21000-050105	23	50 -0,3	49,4	25	M4	38	16	11	10	8	14,5	15,6	22	14,3	50
21000-080110	34	80 -0,5	79	40	M5	60	34	13	12	8	23	22,5	26	14,3	25
21000-080135	34	80 -0,5	79	40	M5	60	34	13	12	8	23	22,5	26	14,3	50
21000-080160	34	80 -0,5	79	40	M5	60	34	13	12	8	23	22,5	26	14,3	75
21000-080185	34	80 -0,5	79	40	M5	60	34	13	12	8	23	22,5	26	14,3	100
21000-120150	45	120 -0,5	119	60	M5	90	40	25	12	8	30	29	26	14,3	25

## Overview of items

Order No.	A	B	B1	B2	D for screw	E	E1	E2	TI	TA	H	I	K	K1	Travel S
21000-120175	45	120 -0,5	119	60	M5	90	40	25	12	8	30	29	26	14,3	50
21000-120200	45	120 -0,5	119	60	M5	90	40	25	12	8	30	29	26	14,3	75
21000-120225	45	120 -0,5	119	60	M5	90	40	25	12	8	30	29	26	14,3	100

Order No.	L	L1	L2	L3	MI	MA	N	O	Y	Spindle	F N	Mx Nm	My Nm	Mz Nm
21000-020030	30	20	38,2	48,2	M2x3	M2x3	M3	3	5,2	M5x0,5	180	0,45	2	0,3
21000-020035	35	20	43,2	53,2	M2x3	M2x3	M3	3	5,2	M5x0,5	180	0,45	2	0,3
21000-020045	45	20	53,2	63,2	M2x3	M2x3	M3	3	5,2	M5x0,5	180	0,45	2	0,3
21000-030040	40	30	48,2	58,2	M3x4,5	M3x4,5	M4	3	5,8	M5x0,5	350	1,1	4	1
21000-030045	45	30	53,2	63,2	M3x4,5	M3x4,5	M4	3	5,8	M5x0,5	350	1,1	4	1
21000-030055	55	30	63,2	73,2	M3x4,5	M3x4,5	M4	3	5,8	M5x0,5	350	1,1	4	1
21000-050067	67	50	78,2	98,2	M4x6	M4x8	M4	5	11,5	M5x0,5	540	2,5	8	2,3
21000-050080	80	50	91,2	111,2	M4x6	M4x8	M4	5	11,5	M5x0,5	540	2,5	8	2,3
21000-050105	105	50	116,2	136,2	M4x6	M4x8	M4	5	11,5	M5x0,5	540	2,5	8	2,3
21000-080110	110	80	128,3	148,3	M5x7,5	M5x10	M6	8	14	M10x1	750	8	22	7
21000-080135	135	80	153,3	173,3	M5x7,5	M5x10	M6	8	14	M10x1	750	8	22	7
21000-080160	160	80	178,3	198,3	M5x7,5	M5x10	M6	8	14	M10x1	750	8	22	7
21000-080185	185	80	203,3	223,3	M5x7,5	M5x10	M6	8	14	M10x1	750	8	22	7
21000-120150	150	120	172,3	192,3	M5x10	M5x10	M6	12	18,5	M10x1	1500	30	45	18
21000-120175	175	120	197,3	217,3	M5x10	M5x10	M6	12	18,5	M10x1	1500	30	45	18
21000-120200	200	120	222,3	242,3	M5x10	M5x10	M6	12	18,5	M10x1	1500	30	45	18
21000-120225	225	120	247,3	267,3	M5x10	M5x10	M6	12	18,5	M10x1	1500	30	45	18