

## Item description/product images



## Description

**Material:**

Steel.

**Version:**

Black oxidised.

**Note:**

The hinge pins should be frequently lubricated. When welding the parts it should be ensured that the function of the hinges is not effected.

The toggle clamp can also be welded directly onto a solid base or a base plate.

Remove the hinge pin D2 before welding and weld the base of the centre piece onto the base or base plate.

After assembly the bracket "A" should be welded to the centre piece.

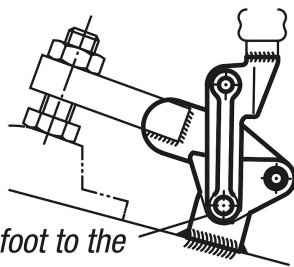

Weld foot to the  
flange parts "A"

## Drawings

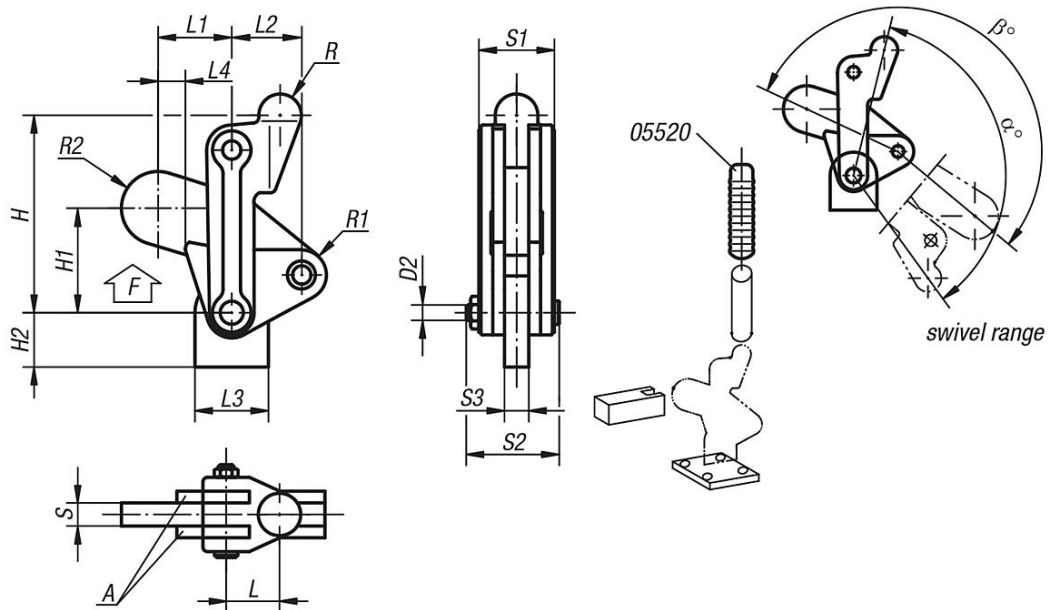

## Overview of items

Order No.	L	L1	L2	L3	L4	H	H1	H2	D2	S	S1	S2	S3	R	R1	R2	$\alpha$	$\beta$	F kN
05420-02	23	26,5	29	29	1,5	84	38,5	20	8,2	10	32	41	10	10	10	13,5	134°	205°	7
05420-04	25	38	36	38	13	100	54	28	9,5	12	38	48	12	11	13	19	134°	203°	12
05420-06	35	51	44	51	10	129	69	33	12,6	16	50	62	16	15	17	22	132°	200°	24