

Item description/product images

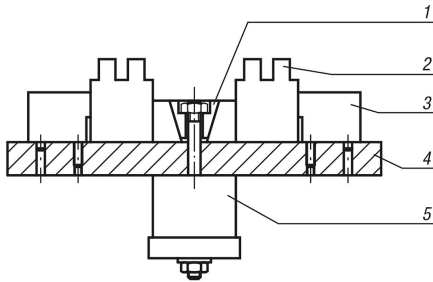
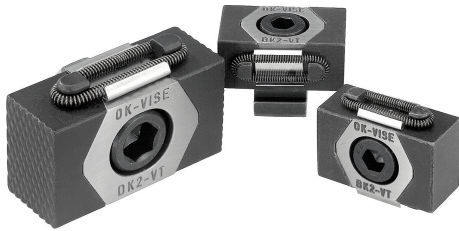

Description

Material:

Body tool steel.

Jaw segments tool steel (30 HRC).

Version:

Body hardened.

Jaw segments black oxidised.

Wedge faces ground.

Note:

The special feature of the wedge clamp lies in the machining allowance per vice jaw of 3 mm for version 04526-08 and 5 mm for versions 04526-12 and 04526-16. This extra length allows for forms adjusted to the workpiece geometry to be incorporated (see illustration).

Vice jaws version 04526-08 and 04526-0810 are not serrated.

Travel acc. to order No.:

04526-08 = ± 0.5 mm

04526-12 = ± 1.0 mm

04526-16 = ± 1.5 mm

On request:

Pre-formed jaw segments or other hardness grades.

Drawing reference:

D) DIN 912 cap screw

- 1) wedge clamps
- 2) workpiece
- 3) fixed stop
- 4) base plate
- 5) hydraulic/pneumatic cylinder

Drawings

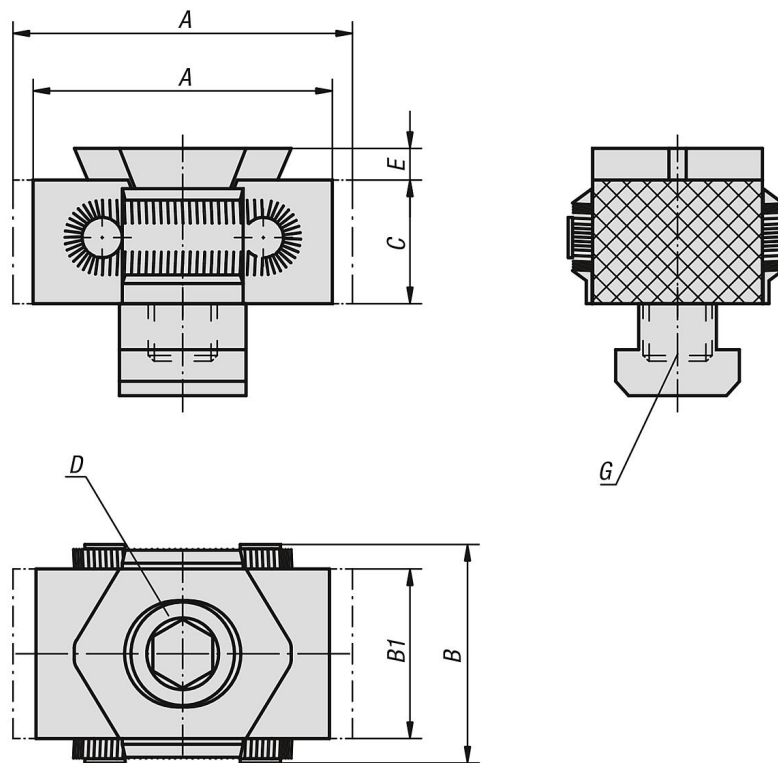

Overview of items

Order No.	A min.	A max.	B	B1	C	D	E	Version 2	G	Clamping force max. kN	Tightening torque max. Nm
04526-08	33	37	29	21	15	M8X25	2,5	for tapped hole	M8	15	25
04526-0810	33	37	29	21	15	M8X25	2,5	for t-slot	10	15	25
04526-12	52	59	41	30	22	M12X40	4	for tapped hole	M12	30	85
04526-1214	52	59	41	30	22	M12X30	4	for t-slot	14	30	85
04526-16	67	76	56	42	29	M16X60	5	for tapped hole	M16	50	210
04526-1618	67	76	56	42	29	M16X50	5	for t-slot	18	50	210