

商品描述/产品说明



产品说明

材料：
手轮，灰口铸铁。

规格：
轮缘经车削和抛光处理。

根据要求：
内四角套筒或者经塑料涂层处理的手轮。

图纸

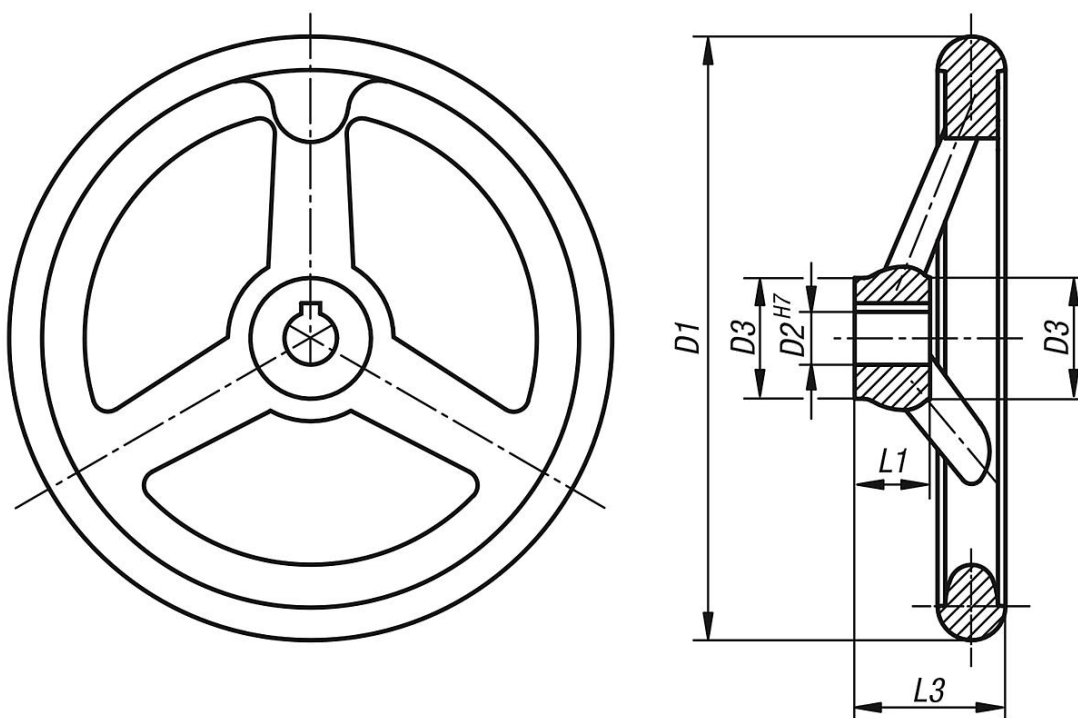

商品概述

订货号 定位孔	订货号 带开槽的定位孔	D1	D2	D3	L1	L3	B3	T	辐条数
06271-0080X10	06271-1080X10	80	10H7	24	16	29	-/3	-/11,4	3
06271-0080X12	06271-1080X12	80	12H7	24	16	29	-/4	-/13,8	3
06271-0100X10	06271-1100X10	100	10H7	26	17	33	-/3	-/11,4	3
06271-0100X12	06271-1100X12	100	12H7	26	17	33	-/4	-/13,8	3
06271-0125X12	06271-1125X12	125	12H7	28	18	36	-/4	-/13,8	3
06271-0125X14	06271-1125X14	125	14H7	28	18	36	-/5	-/16,3	3
06271-0140X14	06271-1140X14	140	14H7	30	19	39	-/5	-/16,3	3
06271-0140X16	06271-1140X16	140	16H7	30	19	39	-/5	-/18,3	3
06271-0160X14	06271-1160X14	160	14H7	32	20	40	-/5	-/16,3	3
06271-0160X16	06271-1160X16	160	16H7	32	20	40	-/5	-/18,3	3
06271-0180X16	06271-1180X16	180	16H7	36	22	43	-/5	-/18,3	3
06271-0180X18	06271-1180X18	180	18H7	36	22	43	-/6	-/20,8	3
06271-0200X18	06271-1200X18	200	18H7	38	24	45	-/6	-/20,8	3
06271-0200X22	06271-1200X22	200	22H7	38	24	45	-/6	-/24,8	3

商品概述

订货号 定位孔	订货号 带开槽的定位孔	D1	D2	D3	L1	L3	B3	T	辐条数
06271-0250X22	06271-1250X22	250	22H7	45	28	50	-/6	-/24,8	5
06271-0250X26	06271-1250X26	250	26H7	45	28	50	-/8	-/29,3	5
06271-0315X26	06271-1315X26	315	26H7	53	33	56	-/8	-/29,3	5
06271-0315X30	06271-1315X30	315	30H7	53	33	56	-/8	-/33,3	5
06271-0400X30	06271-1400X30	400	30H7	65	38	63	-/8	-/33,3	5
06271-0400X34	06271-1400X34	400	34H7	65	38	63	-/10	-/37,3	5
06271-0500X34	06271-1500X34	500	34H7	78	45	72	-/10	-/37,3	5
06271-0500X40	06271-1500X40	500	40H7	78	45	72	-/12	-/43,3	5