

## 商品描述/产品说明



## 产品说明

材料：  
不锈钢 1.4404。

规格：  
经抛光或喷丸处理。

订购须知：  
单独订购紧固材料和末端垫片。

附件：  
末端垫片 06922-11。  
垫片 07300。  
垫片 07305。  
六角螺栓 07171。  
螺栓 07174。  
圆柱头螺栓 07160。

## 商品描述/产品说明



## 图纸

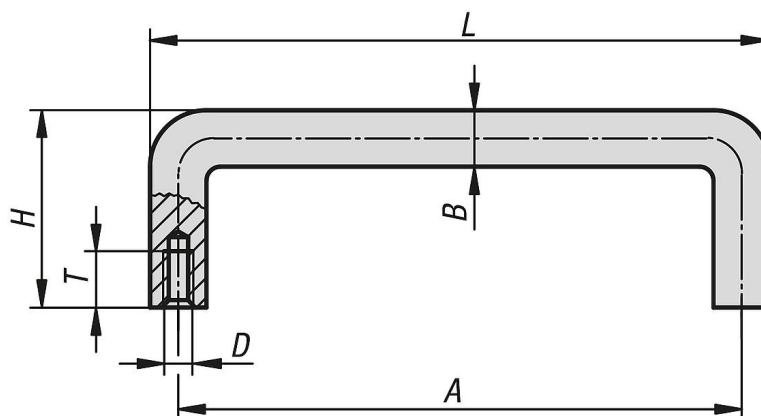

## 商品概述

订货号	主体表面	A	B	D	H	T	L	负载能力 N
06922-10-032031	亮面抛光	32	5	M3	24	6	37	500
06922-10-042031	亮面抛光	42	5	M3	24	6	47	500
06922-10-055031	亮面抛光	55	5	M3	24	6	60	500
06922-10-064031	亮面抛光	64	5	M3	24	6	69	500
06922-10-076031	亮面抛光	76	5	M3	24	6	81	500
06922-10-088031	亮面抛光	88	5	M3	24	6	93	500
06922-10-032041	亮面抛光	32	8	M4	32	8	40	500
06922-10-042041	亮面抛光	42	8	M4	32	8	50	500
06922-10-055041	亮面抛光	55	8	M4	32	8	63	500
06922-10-064041	亮面抛光	64	8	M4	32	8	72	500
06922-10-076041	亮面抛光	76	8	M4	32	8	84	500
06922-10-088041	亮面抛光	88	8	M4	32	8	96	500
06922-10-096041	亮面抛光	96	8	M4	32	8	104	500
06922-10-098041	亮面抛光	98	8	M4	32	8	106	500
06922-10-100041	亮面抛光	100	8	M4	32	8	108	500
06922-10-102041	亮面抛光	102	8	M4	32	8	110	500
06922-10-120041	亮面抛光	120	8	M4	32	8	128	500
06922-10-136041	亮面抛光	136	8	M4	32	8	144	500
06922-10-055051	亮面抛光	55	10	M5	40	10	65	1000
06922-10-064051	亮面抛光	64	10	M5	40	10	74	1000
06922-10-076051	亮面抛光	76	10	M5	40	10	86	1000
06922-10-088051	亮面抛光	88	10	M5	40	10	98	1000
06922-10-096051	亮面抛光	96	10	M5	40	10	106	1000

## 商品概述

订货号	主体表面	A	B	D	H	T	L	负载能力 N
06922-10-098051	亮面抛光	98	10	M5	40	10	108	1000
06922-10-100051	亮面抛光	100	10	M5	40	10	110	1000
06922-10-102051	亮面抛光	102	10	M5	40	10	112	1000
06922-10-120051	亮面抛光	120	10	M5	40	10	130	1000
06922-10-136051	亮面抛光	136	10	M5	40	10	146	1000
06922-10-140051	亮面抛光	140	10	M5	40	10	150	1000
06922-10-160051	亮面抛光	160	10	M5	40	10	170	1000
06922-10-180051	亮面抛光	180	10	M5	40	10	190	1000
06922-10-200051	亮面抛光	200	10	M5	40	10	210	1000
06922-10-235051	亮面抛光	235	10	M5	40	10	245	1000
06922-10-250051	亮面抛光	250	10	M5	40	10	260	1000
06922-10-300051	亮面抛光	300	10	M5	40	10	310	1000
06922-10-350051	亮面抛光	350	10	M5	40	10	360	1000
06922-10-120061	亮面抛光	120	12	M6	42	12	132	1000
06922-10-136061	亮面抛光	136	12	M6	42	12	148	1000
06922-10-140061	亮面抛光	140	12	M6	42	12	152	1000
06922-10-160061	亮面抛光	160	12	M6	42	12	172	1000
06922-10-180061	亮面抛光	180	12	M6	42	12	192	1000
06922-10-200061	亮面抛光	200	12	M6	42	12	212	1000
06922-10-235061	亮面抛光	235	12	M6	42	12	247	1000
06922-10-250061	亮面抛光	250	12	M6	42	12	262	1000
06922-10-300061	亮面抛光	300	12	M6	42	12	312	1000
06922-10-350061	亮面抛光	350	12	M6	42	12	362	1000
06922-10-140081	亮面抛光	140	16	M8	58	12	156	1000
06922-10-160081	亮面抛光	160	16	M8	58	12	176	1000
06922-10-180081	亮面抛光	180	16	M8	58	12	196	1000
06922-10-200081	亮面抛光	200	16	M8	58	12	216	1000
06922-10-235081	亮面抛光	235	16	M8	58	12	251	1000
06922-10-250081	亮面抛光	250	16	M8	58	12	266	1000
06922-10-300081	亮面抛光	300	16	M8	58	12	316	1000
06922-10-350081	亮面抛光	350	16	M8	58	12	366	1000
06922-10-032033	亚光喷丸	32	5	M3	24	6	37	500
06922-10-042033	亚光喷丸	42	5	M3	24	6	47	500
06922-10-055033	亚光喷丸	55	5	M3	24	6	60	500
06922-10-064033	亚光喷丸	64	5	M3	24	6	69	500
06922-10-076033	亚光喷丸	76	5	M3	24	6	81	500
06922-10-088033	亚光喷丸	88	5	M3	24	6	93	500
06922-10-032043	亚光喷丸	32	8	M4	32	8	40	500
06922-10-042043	亚光喷丸	42	8	M4	32	8	50	500
06922-10-055043	亚光喷丸	55	8	M4	32	8	63	500
06922-10-064043	亚光喷丸	64	8	M4	32	8	72	500
06922-10-076043	亚光喷丸	76	8	M4	32	8	84	500
06922-10-088043	亚光喷丸	88	8	M4	32	8	96	500
06922-10-096043	亚光喷丸	96	8	M4	32	8	104	500
06922-10-098043	亚光喷丸	98	8	M4	32	8	106	500
06922-10-100043	亚光喷丸	100	8	M4	32	8	108	500
06922-10-102043	亚光喷丸	102	8	M4	32	8	110	500
06922-10-120043	亚光喷丸	120	8	M4	32	8	128	500
06922-10-136043	亚光喷丸	136	8	M4	32	8	144	500
06922-10-055053	亚光喷丸	55	10	M5	40	10	65	1000
06922-10-064053	亚光喷丸	64	10	M5	40	10	74	1000
06922-10-076053	亚光喷丸	76	10	M5	40	10	86	1000
06922-10-088053	亚光喷丸	88	10	M5	40	10	98	1000
06922-10-096053	亚光喷丸	96	10	M5	40	10	106	1000
06922-10-098053	亚光喷丸	98	10	M5	40	10	108	1000
06922-10-100053	亚光喷丸	100	10	M5	40	10	110	1000
06922-10-102053	亚光喷丸	102	10	M5	40	10	112	1000
06922-10-120053	亚光喷丸	120	10	M5	40	10	130	1000
06922-10-136053	亚光喷丸	136	10	M5	40	10	146	1000
06922-10-140053	亚光喷丸	140	10	M5	40	10	150	1000
06922-10-160053	亚光喷丸	160	10	M5	40	10	170	1000
06922-10-180053	亚光喷丸	180	10	M5	40	10	190	1000
06922-10-200053	亚光喷丸	200	10	M5	40	10	210	1000
06922-10-235053	亚光喷丸	235	10	M5	40	10	245	1000
06922-10-250053	亚光喷丸	250	10	M5	40	10	260	1000

## 商品概述

订货号	主体表面	A	B	D	H	T	L	负载能力 N
06922-10-300053	亚光喷丸	300	10	M5	40	10	310	1000
06922-10-350053	亚光喷丸	350	10	M5	40	10	360	1000
06922-10-120063	亚光喷丸	120	12	M6	42	12	132	1000
06922-10-136063	亚光喷丸	136	12	M6	42	12	148	1000
06922-10-140063	亚光喷丸	140	12	M6	42	12	152	1000
06922-10-160063	亚光喷丸	160	12	M6	42	12	172	1000
06922-10-180063	亚光喷丸	180	12	M6	42	12	192	1000
06922-10-200063	亚光喷丸	200	12	M6	42	12	212	1000
06922-10-235063	亚光喷丸	235	12	M6	42	12	247	1000
06922-10-250063	亚光喷丸	250	12	M6	42	12	262	1000
06922-10-300063	亚光喷丸	300	12	M6	42	12	312	1000
06922-10-350063	亚光喷丸	350	12	M6	42	12	362	1000
06922-10-140083	亚光喷丸	140	16	M8	58	12	156	1000
06922-10-160083	亚光喷丸	160	16	M8	58	12	176	1000
06922-10-180083	亚光喷丸	180	16	M8	58	12	196	1000
06922-10-200083	亚光喷丸	200	16	M8	58	12	216	1000
06922-10-235083	亚光喷丸	235	16	M8	58	12	251	1000
06922-10-250083	亚光喷丸	250	16	M8	58	12	266	1000
06922-10-300083	亚光喷丸	300	16	M8	58	12	316	1000
06922-10-350083	亚光喷丸	350	16	M8	58	12	366	1000