

OPERATING INSTRUCTIONS
3-AXIS CLAMPING SYSTEM

Contents :

1. Introduction
2. Safety and Warnings
- 3.1 Description of the clamping system
- 3.2 Specifications
- 3.3 Assembling the clamping system
- 3.4 Work stop
- 3.5 Clamping cylindrical parts
- 4 Mounting the clamping system
5. Care and maintenance
6. Service

1. Introduction

Before using the 3-axis clamping system, please read the information in these instructions carefully.

The clamping system can cause serious material damage if it is operated or assembled incorrectly.

Norelem is under no circumstances responsible for any type of damage regardless of how this damage is caused.

Description

The 3-axis clamping system has been designed for flexible use and an extremely long service life. It is made of high-quality steel. The 3-axis clamping system is ideal for single and serial manufacturing with a maximum clamping width of 236 mm (standard version) that can be extended as required. It is recommended that only original accessories be used with the 3-axis clamping system.

2. Safety and Warnings

- Do not exceed the maximum tightening torque of 120 Nm
- Check that everything is correctly and securely assembled
- Always clamp the workpiece in the centre of the jaw
- Check that all the screw connections are completely tightened. Check regularly.
- The clamped workpiece may have a maximum parallel displacement of 0.5 mm along the entire clamping width



- Flat pin:
for use with material over 1000 N/mm²



- Pin with ring cutter:
for use with material up to 1000 N/mm²



- The spindle nut (8) may not protrude over the marking on the threaded spindle (7) (Fig. 1).

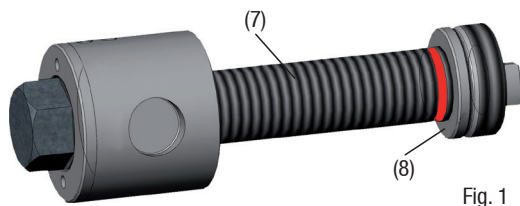
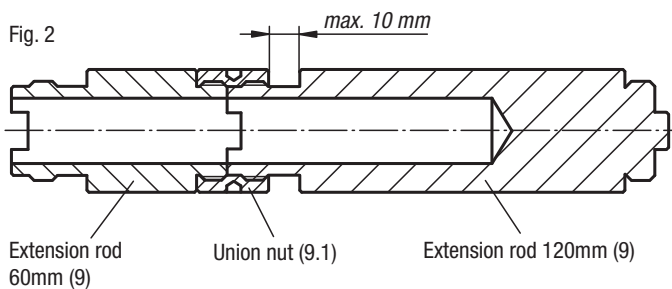

Fig. 1

- When assembled, the spacing between the union nut (9.1) and the extension rod (9) may not exceed 10 mm (Fig. 2).



- Only move the sliding jaws (2) within the markings (Fig. 3).

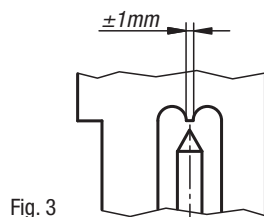
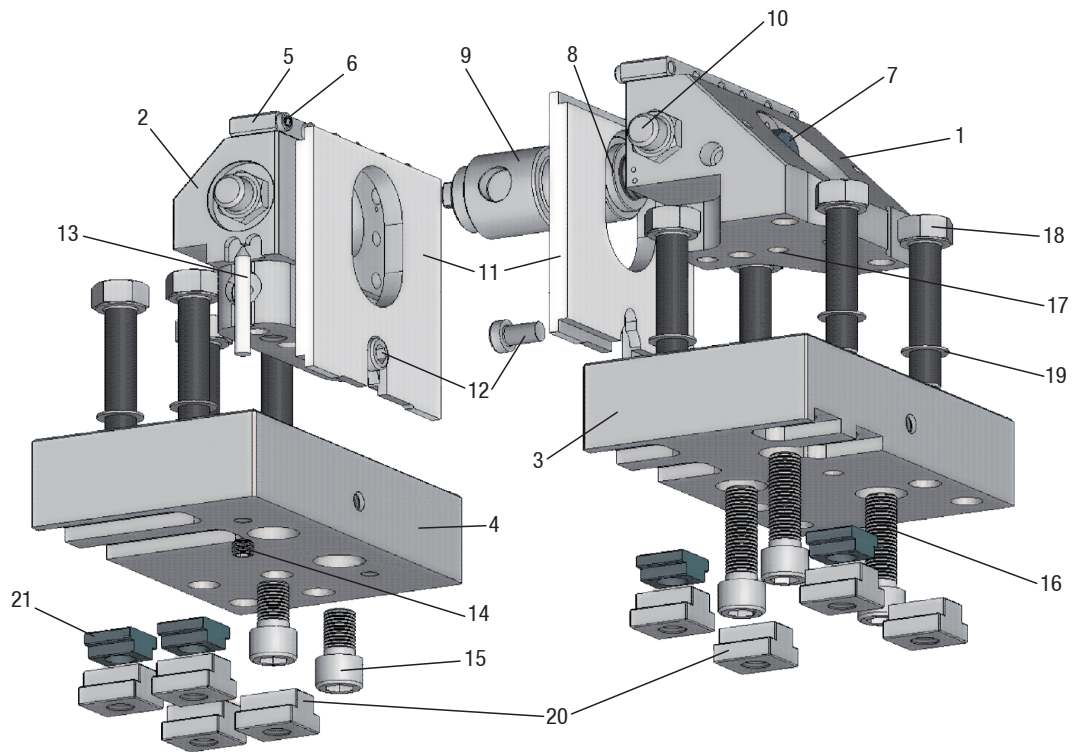

Fig. 3

3.1 Description of clamping system



1	Fixed jaw
2	Sliding jaw
3	Base plate for fixed jaw
4	Base plate for sliding jaw
5	Clamping jaw, standard
6	Clamping pins
7	Threaded spindle with traction housing (7.1)
8	Spindle nut
9	Extension rod with union nut (9.1)
10	Fastening screw
11	Seating ledge
12	DIN 6912 M8x14 socket head screw
13	Indicator
14	DIN 913 M8x8 grub screw
15	DIN 912 M12x20 socket head screw
16	DIN 912 M12x40 socket head screw
17	DIN 7979 8x20 dowel pin
18	DIN 931 M12x60 hex head screw
19	Washer
20	T-slot nut
21	Locating slot nut

3.2 Specifications

Clamping force 3-axis clamping system

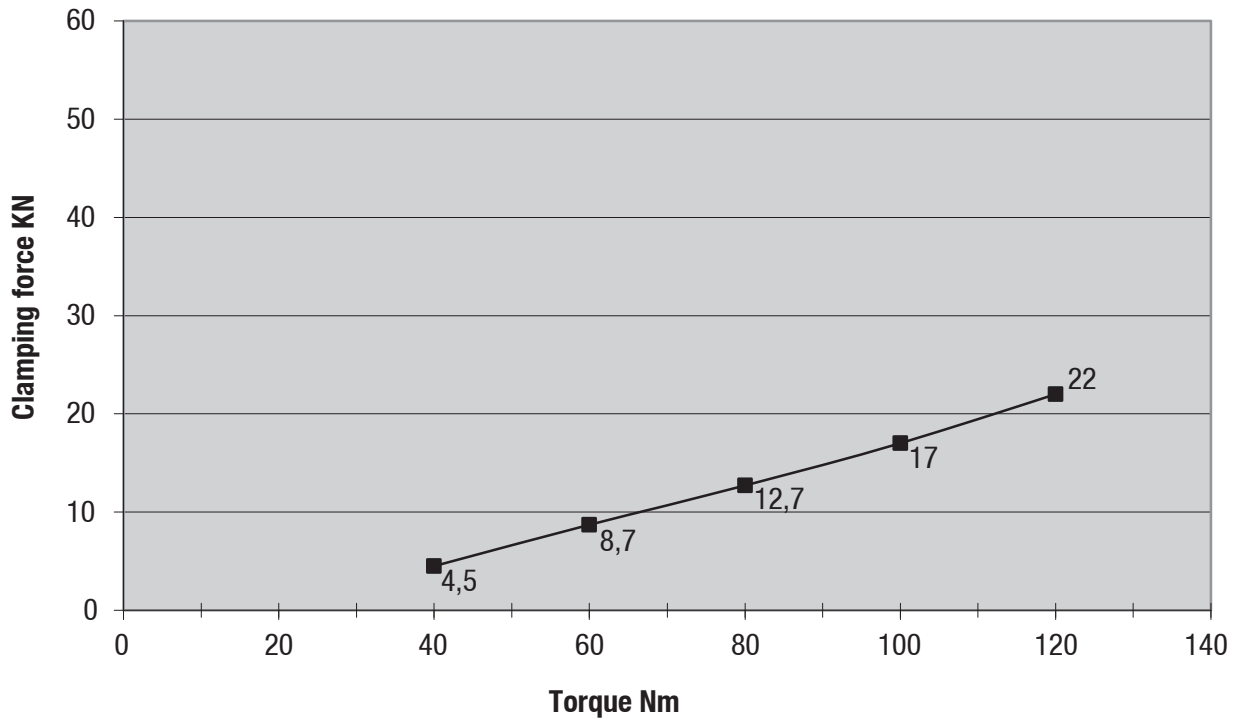

The permitted torque of 120 Nm may not be exceeded.

3-axis clamping system specifications	
Clamping height over machine table	100 mm
Jaw width	100 mm
Clamping force on workpiece	0 - 22 kN
Clamping width (basic set)	22 - 236 mm

3.3 Assembling the clamping system

- 3.3.1 Insert the mounting screws (18) including washers (19) into the base plate (4) (no longer possible after mounting the sliding jaw).
- 3.3.2 Insert the sliding jaw (2) into the base plate (4) and insert screws (15).
- 3.3.3 Tighten both DIN 912 M12x20 fastening screws (15) to 140 Nm.
- 3.3.4 Tap the indicator (13) into the hole provided on the operators side from underneath and secure with the DIN 913 grub screw (14). The distance between the indicator and the marking should be 0.5 mm.
- 3.3.5 Attach the seating ledge (11) flush with the clamping surface of the base plate (4) using the DIN 6912 mounting screws (12) and tighten to 20 Nm.
- 3.3.6 Tap both DIN 7979 dowels (17) into the holes provided in the fixed jaw (1) until they stop (internal thread facing outward).
- 3.3.7 Insert the mounting screws (18) including washers (19) into the base plate (3) (no longer possible after mounting the fixed jaw).
- 3.3.8 Position the fixed jaw (1) on the base plate (3) using the dowel pins.
- 3.3.9 Tighten the three DIN 912 M12x40 fastening screws (16) to 140 Nm.
- 3.3.10 Attach the seating ledge (11) flush with the clamping surface of the base plate (3) with the DIN 6912 fastening screws (12) and tighten to 20 Nm.

3.4 Work stop

The work stop can be mounted either fixed or to swivel. The stop can be swung down to allow machining on the workpiece stop face. It engages with a spring plunger.

The stop can be mounted on both sides on the fixed jaw.

- 3.4.1 Mount the stop as shown in the illustration. Make sure that only the ball of the spring plunger (25) is projecting from the back of the work stop arm (20)!
- 3.4.2 Tighten the screw (23) only so much so that the work stop can still swivel (if required). Secure screw (23) with grub screw (27).
- 3.4.3 Slide the stop pin (22) into position and clamp with the screw (26).

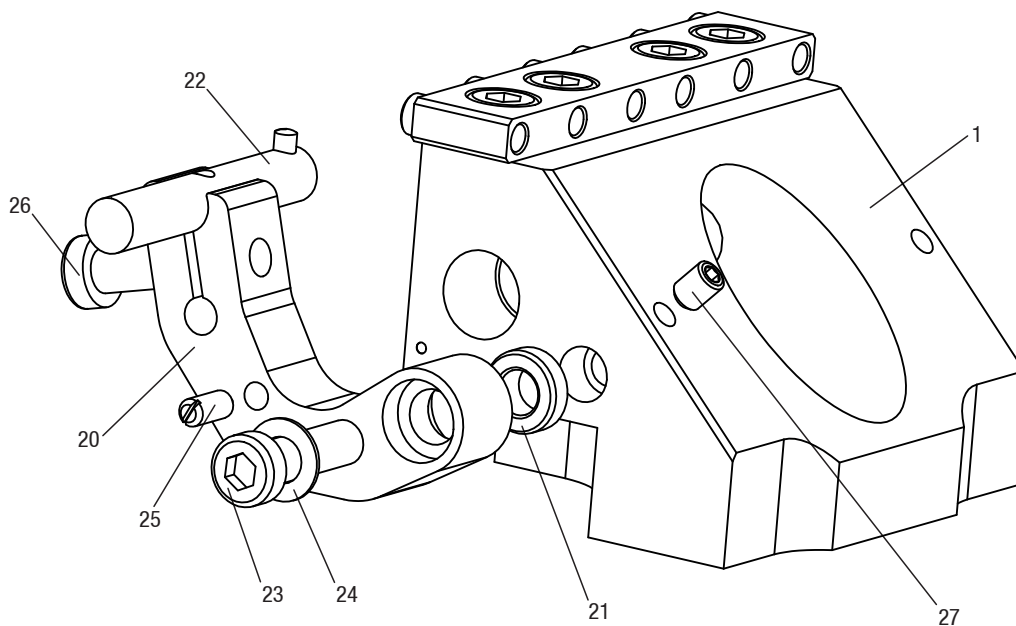

1	Fixed jaw
20	Work stop arm
21	Centring ring
22	Stop pin
23	DIN 6912 M8x30 socket head screw
24	Spring washer
25	Spring plunger
26	DIN 6912 M6x14 socket head screw
27	DIN 913 M6x8 grub screw

3.5 Clamping cylindrical parts

The cylinder clamping buttons (31) must be aligned to the workpiece centre.

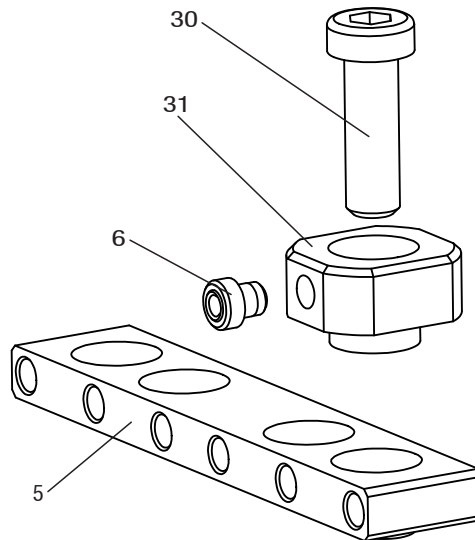
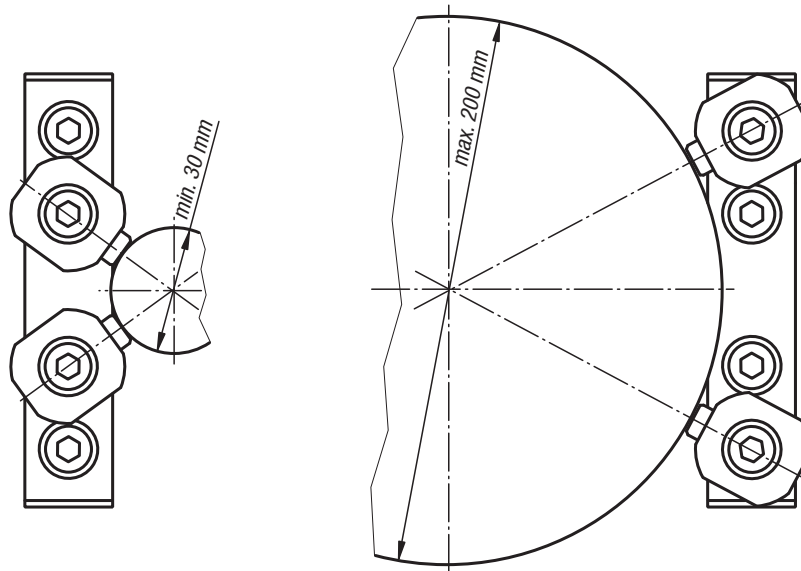

30	Socket head screw
31	Cylinder clamping button
5	Clamping jaw, standard
6	Clamping pins

4. Mounting the clamping system

- Position the fixed jaws (1) incl. base plate (3) on the machine table (or grid plate) using the locating slot nuts (21) (or clamps) and tighten the DIN 931 screws with the washers (18, 19) to 90 Nm.
- Insert the threaded spindle (7) into the jaws and tighten both locking screws (10) by hand until they stop in the pocket provided on the traction housing (7.1) of the threaded spindle. Now use a socket wrench to tighten the locking screws (10) as required (tightening by hand is in most cases sufficient).
- Adjust the length of the clamping rod to the length of the workpiece using the various extension rods (9):

- Extension rod 60 (9)
= workpiece length 22 - 86 mm

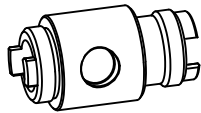

- Extension rod 120 (9)
= workpiece length 80 - 146 mm

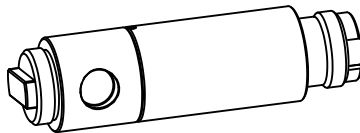

- Extension rod 240 (9)
= extension by 240 mm

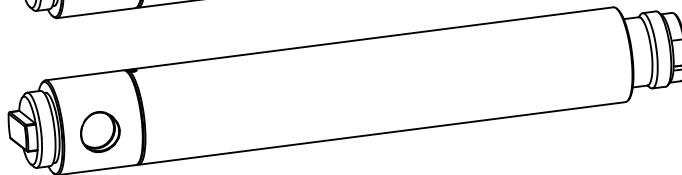

- Extension rod 60 + 120
= workpiece length 140 - 206 mm

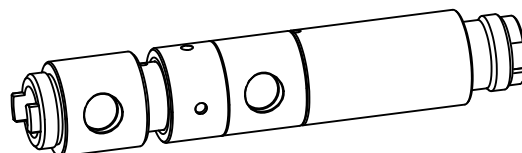

- Extension rod 60 + 120
= workpiece length 170 - 236 mm
(with jaws rotated 180°)

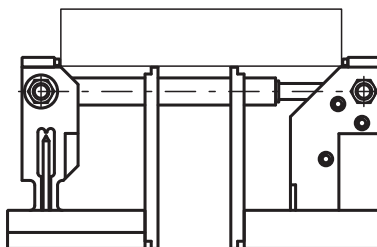

- For longer workpieces more extension rods must be added.

- Move sliding jaw (2) incl. base plate (4) with pre-assembled seating ledge (11) into position.
- **!!! Important !!!**
Leave only a maximum of 1 mm clearance to the workpiece. The indicator (13) must be located in the centre position. Screw the sliding jaw (2) incl. the base plate (4) in this position to the table or grid plate.
- Insert the extension rod (9) including union nut through the sliding jaw (2) and join with the spindle nut (8). Screw the extension rod (9) onto the threaded spindle (7) until both locking screws (10) engage into the pockets provided on the extension rods (9). At the same time observe the marking (notch) on the extension rod (9). The notch on the extension rod (9) must be flush with the sliding jaw. The centring hole on the extension rod (9) must be facing vertically upwards so that the locking screws (10) can be inserted into the pockets on the extension rods.

Mounting on grid plates

- Tighten the shoulder screws adequately:
M12 = ca. 80 Nm
M16 = ca. 170 Nm

Mounting on grid plates using clamps

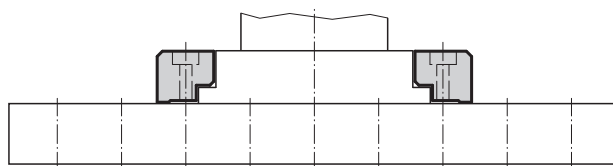

Mounting on grid plates using end clamps and middle clamps

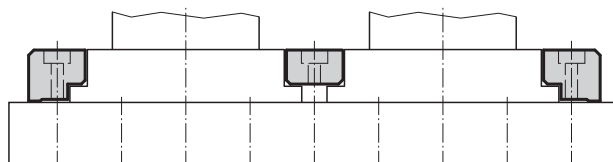

5. Care and maintenance

It should be ensure that the threads are clean and not damaged.
A light oil film is required on all parts.

6. Service

norelem Normelemente GmbH & Co. KG
Volmarstraße 1
71706 Markgröningen

www.norelem.com
info@norelem.com

Reproduction, transfer, distribution, or storage of part or all of the contents in this document in any form without the prior written permission of norelem Normelemente GmbH & Co. KG is prohibited.

norelem Normelemente GmbH & Co. KG continuously develops its products in compliance with its own policy. norelem Normelemente GmbH & Co. KG reserves the right to make changes and improvements to any of the products described in this document without prior notice.

norelem Normelemente GmbH & Co. KG is under no circumstances responsible for any type of special, incidental, consequential or indirect damage regardless of how this damage is caused.

The contents of this document are presented in its current version. norelem Normelemente GmbH & Co. KG does not assume any warranty, whether explicitly or implicitly, for the correctness or completeness of the content of this document including, but not limited to, the implied warranties of merchantability and fitness for a particular purpose, unless the applicable laws or case law should make such liability mandatory. norelem Normelemente GmbH & Co. KG reserves the right to make changes to this document or withdraw this document without prior notice.